

TP-201

AUTO P.P. STRAPPING MACHINE

A DURABLE SEMI-AUTO STRAPPING MACHINE

- Stability: Uniform mass production by CNC machine center.
 - Superiority: P. C. Board electric control.
 - Versatility: Adjustment to use strap between 6mm to 15.5mm.
 - Reliability: Low maintenance.
 - Convenience: Hinged top plate, easy for maintenance. Adjustable strap dispenser: Suitable for strap core 200mm, 230mm & 280mm.
- * Option. Stainless steel frame (SUS 304)

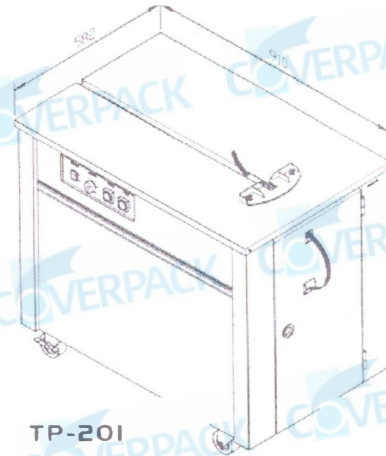

TP-201

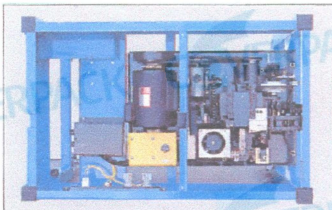

• Durable Control I lead

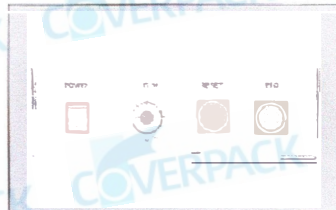

• Simple Operation Panel

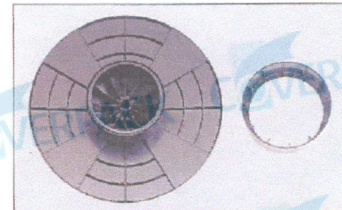

• Patented Adjustable Dispenser

SPECIFICATIONS

MODEL	* TP-201
Strapping Speed	2.5sec/strap
Dimension	910mm(L) × 582mm(W) × 785mm(H)
Net Weight	100KGS
Max. Tension	45KGS
Strap Width	6, 9, 12, 15.5mm
Power	AC1 10V, 220V, 230V (50/60Hz), 1 phase

* CE and GS models are available on request.

TP-202 Semi-Auto

- Mechanical outside tension control
- Strap width : 6mm to 15.5mm adjustable
- Hinged top plate
- Power : 110V, 220V, 230V, 240V 50/60Hz Single phase

Options

- Adjustable table height from 760mm to 930mm(TP-202)
- TP-201 Enclosed Frame
- TP-203 Mini Type



- TP-201Y Side Sealing
Stainless steel frame SUS 304



- TP-202L Low Table

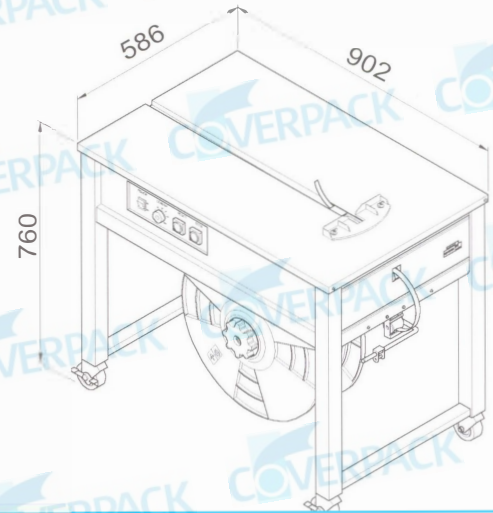
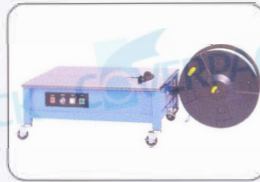

COVERPACK DE MEXICO S DE RL DE CV/ VENTAS3@COVERPACK.COM.MX
8183505758 / CAMINO AL MILAGRO 106 APODACA, NUEVO LEON.